

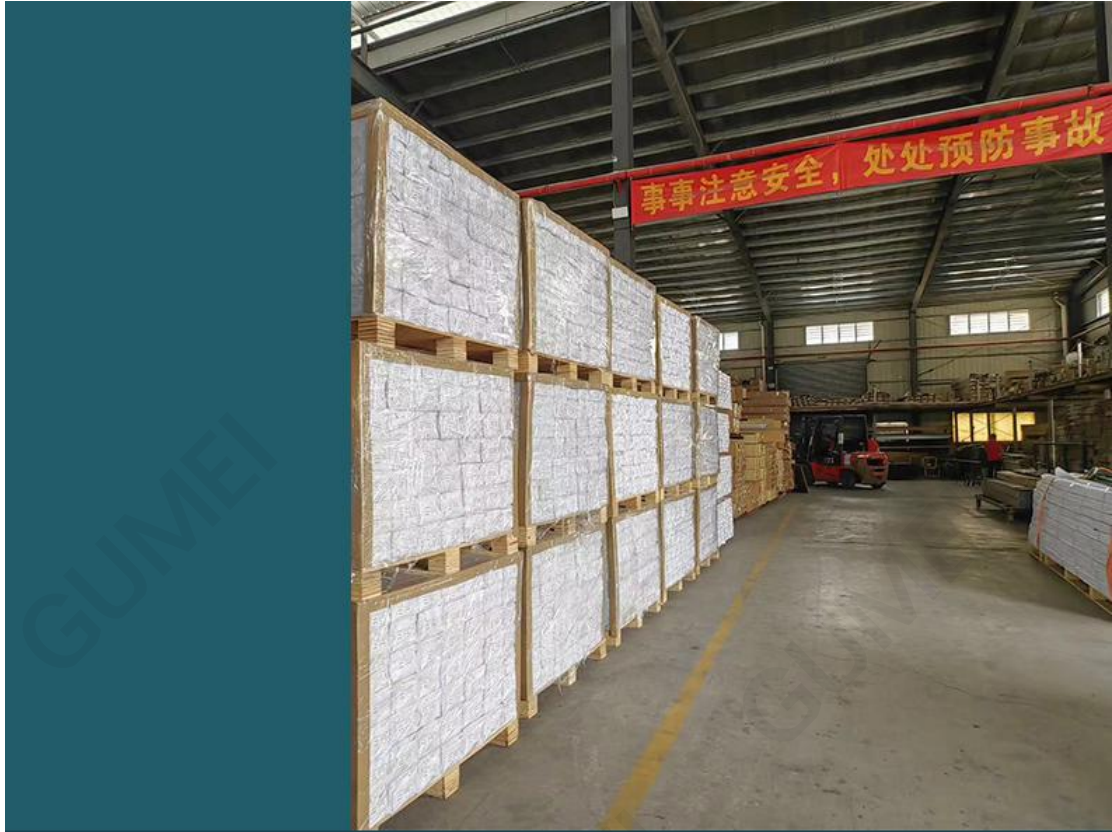

40条挤出生产线为您服务

40 extrusion lines at your service





专业的管理体系

Professional Management System



PVC OUTDOOR

ASA co-extrusion process



PVC 户外

ASA共挤工艺

PVC OUTDOOR

ASA co-extrusion process

PVC is extremely plastic and has a certain degree of flame retardancy, in addition, ASA modified plastic (ASA plastic is made by copolymerization of styrene, acrylonitrile and acrylate rubber body. In terms of technology, Asa not only maintains the main properties of ABS, but also combines the advantages of weather resistance of PMMA, making the application of the product can be extended to outdoor use) co-extrusion layer, the utility model improves the service life of the plate for outdoor use.

PVC 户外

ASA共挤工艺

pvc具有极高的可塑形，并且具有一定的阻燃性能，加上asa改性塑料（ASA塑料是由苯乙烯、丙烯腈和丙烯酸酯类橡胶体共聚合而成。在技术上而言，ASA不仅维持了ABS之主要特性，并结合PMMA耐候之优点，使得产品之应用上可延伸至户外之用途）的共挤层，提高了板材用于户外的使用寿命。

ASA co-extrusion with stronger wooden texture



ASA 共挤工艺 木质感更强





户外ASA共挤塑木系列

pvc具有极高的可塑形，并具有一定的阻燃性能，加上ASA改性塑料(ASA塑料是由苯乙烯、丙烯腈和丙烯酸酯类橡胶体共聚而成。在技术上而言，ASA不仅维持了ABS之主要特性，并结合PMMA耐候之优点，使得产品之应用上可延伸至户外之用途)的共挤层，提高了板材用于户外的使用寿命。

Outdoor ASA wall panel

PVC is extremely plastic and has a certain degree of flame retardancy, in addition, ASA modified plastic (ASA plastic is made by copolymerization of styrene, acrylonitrile and acrylate rubber body. In terms of technology, Asa not only maintains the main properties of ABS, but also combines the advantages of weather resistance of PMMA, making the application of the product can be extended to outdoor use) co-extrusion layer, the utility model improves the service life of the plate for outdoor use.

户外ASA共挤塑木系列 Outdoor ASA wall panel

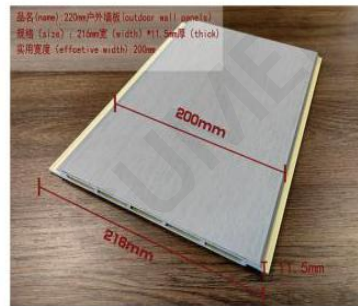
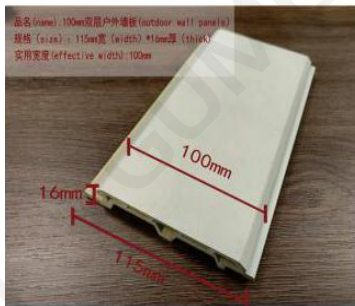
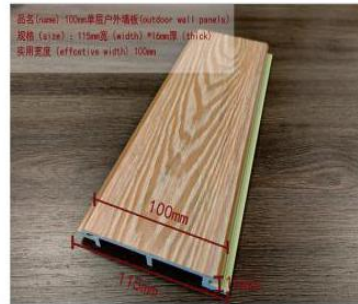

PVC OUTDOOR

Color sample

The picture is for
reference only
图片仅供参考，颜色以实物为准

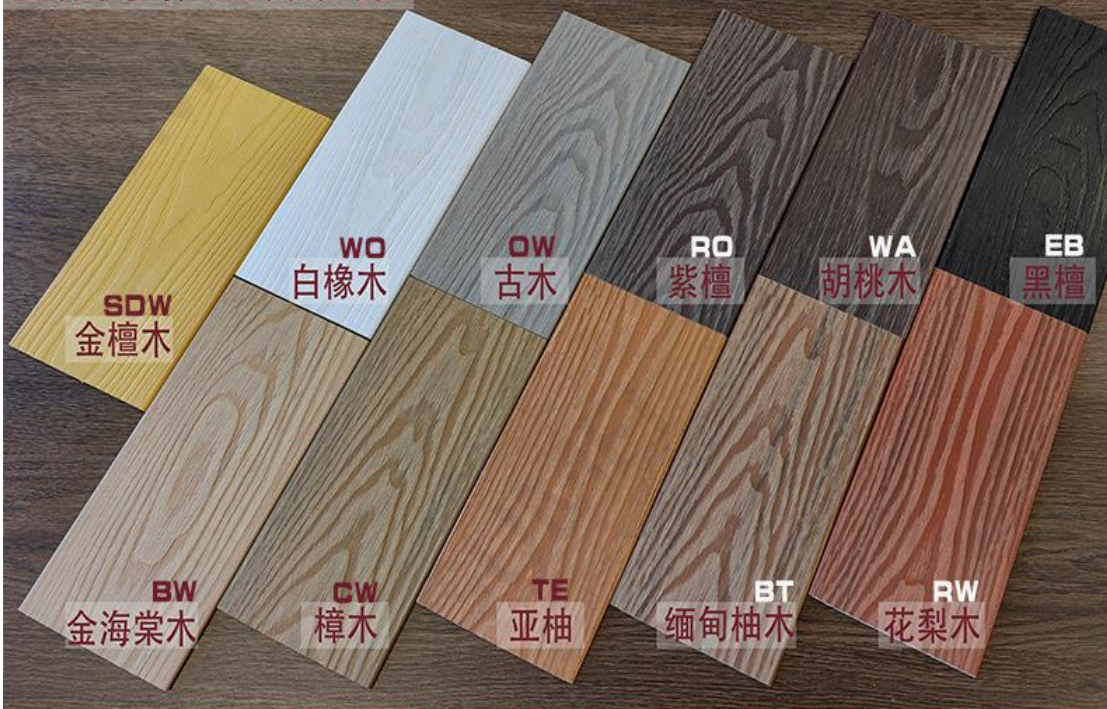

PVC 户外 色卡



ASA co-extrusion PVC OUTDOOR

Various of Designs

品名 (name): 100mm单层户外墙板 (outdoor wall panels)

规格 (size): 115mm宽 (width) * 16mm厚 (thick)

实用宽度 (effective width): 100mm

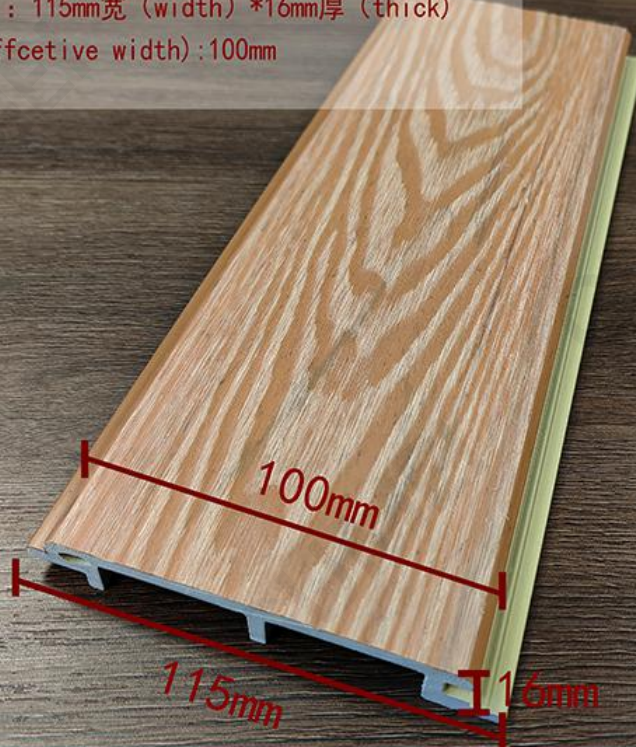

PVC 户外 ASA共挤



ASA co-extrusion PVC OUTDOOR

Various of Designs

品名 (name): 100mm 双层户外墙板 (outdoor wall panels)

规格 (size): 115mm 宽 (width) * 16mm 厚 (thick)

实用宽度 (effective width): 100mm

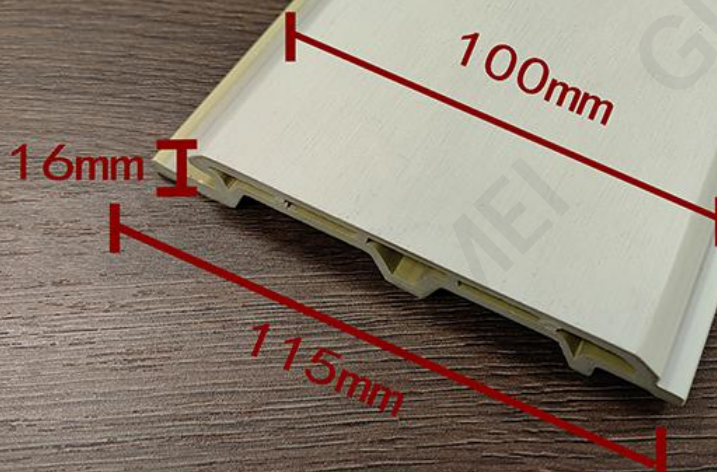

PVC 户外 ASA 共挤



ASA co-extrusion PVC OUTDOOR

Various of Designs

品名 (name): 150mm单层户外墙板 (outdoor wall panels)

规格 (size): 170mm宽 (width) * 15mm厚 (thick)

实用宽度 (effective width): 150mm



PVC 户外 ASA共挤



ASA co-extrusion PVC OUTDOOR

Various of Designs

品名 (name): 160mm户外格栅 (outdoor wall panels)
规格 (size): 173.5mm宽 (width) * 16mm厚 (thick)
实用宽度 (effective width): 160mm



PVC 户外 ASA共挤



ASA co-extrusion PVC OUTDOOR

Various of Designs

品名 (name): 200mm 户外格栅 (outdoor wall panels)
规格 (size): 219mm 宽 (width) * 24mm 厚 (thick)
实用宽度 (effective width): 200mm

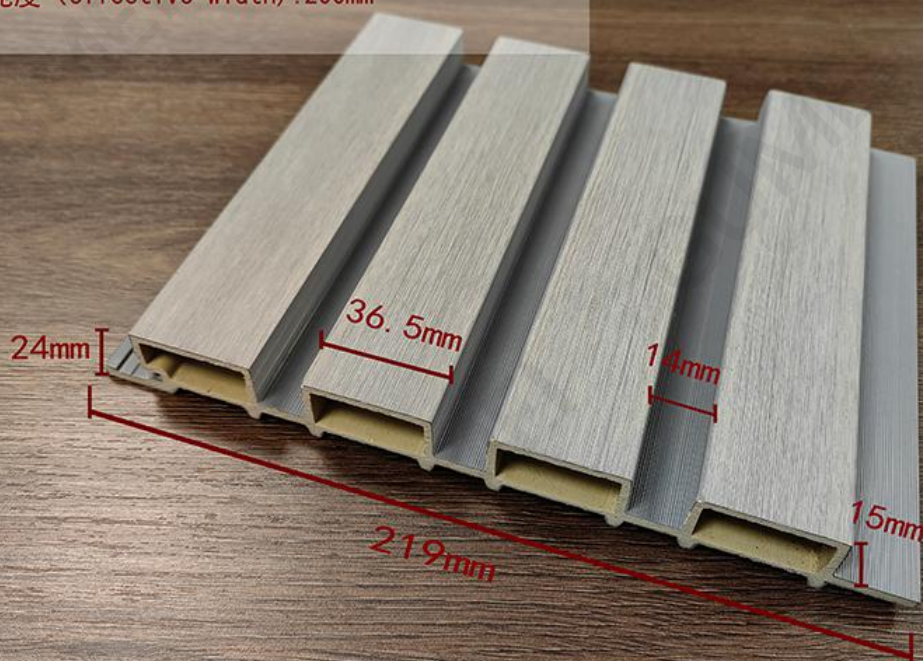

PVC 户外 ASA 共挤



ASA co-extrusion PVC OUTDOOR

Various of Designs

品名 (name): 220mm户外墙板 (outdoor wall panels)
规格 (size): 216mm宽 (width) * 11.5mm厚 (thick)
实用宽度 (effective width): 200mm

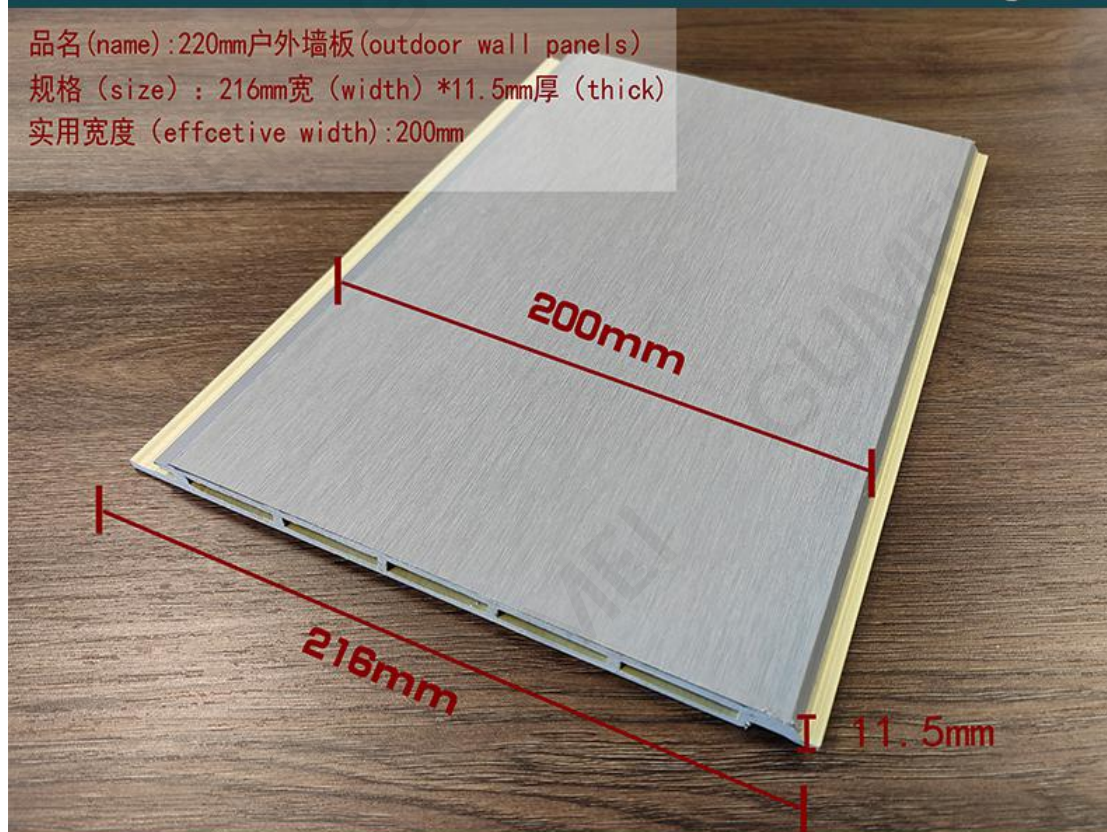

PVC 户外 ASA共挤



ASA co-extrusion PVC OUTDOOR

Various of Designs

品名 (name) : 户外子母格栅 (outdoor wall panels)

规格 (size) : 149mm宽 (width) * 13.5mm厚 (thick)

实用宽度 (effective width): 140mm

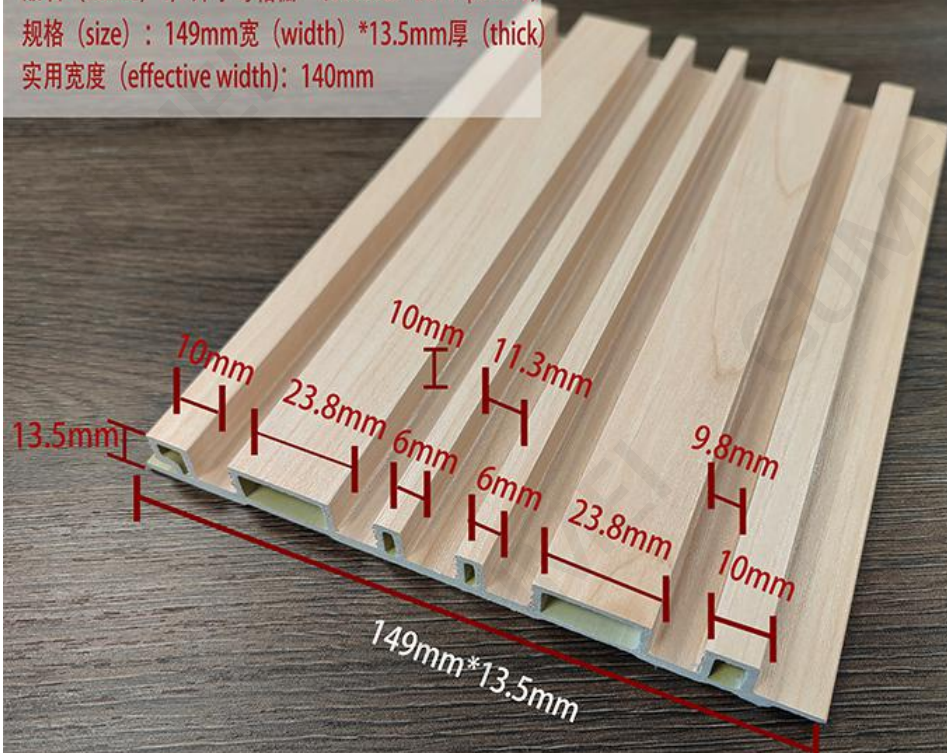

PVC 户外 ASA共挤



ASA co-extrusion PVC OUTDOOR

Various of Designs

品名(name): 户外地板 (outdoor floor)
规格(size): 140mm宽 (width) *25mm厚 (thick)



PVC 户外 ASA共挤



PVC INDOOR



pur glue paste

PVC 室内
PUR环保热胶覆膜

户外一代PE3D压纹塑木系列 Outdoor Generation PE 3D embossing Series

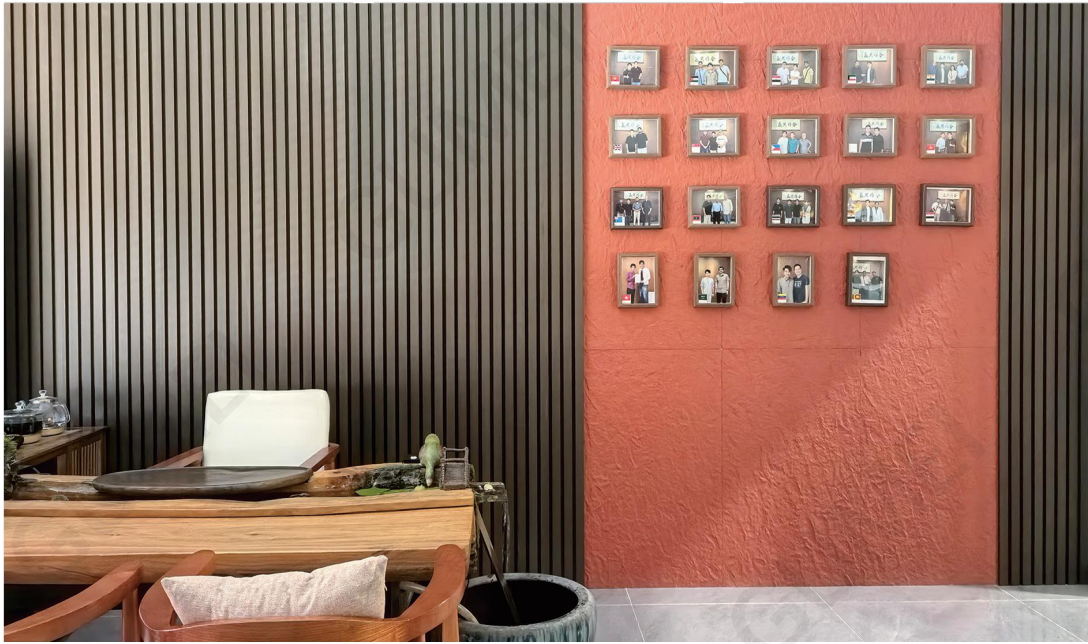

PVC室内 PUR环保热胶覆膜

木塑共挤墙板具有先进的坚硬塑料保护层，该保护层包裹在WPC芯体的四周，以提供附加的保护。它结合了木塑复合材料的韧性、寿命和工程设计。挤压过程使它具有高度抗污渍和抗紫外线和超低维护成本的优点。它不需要刷漆，只需定期清洁即可亮丽如新。有六种颜色可供选择，木纹清晰，具有天然木材的丰富性和木质感。

PVC INDOOR--pur glue paste

The wood-plastic co-extrusion wall panel has an advanced hard plastic protective layer, which wraps around the four sides of the WPC core provide additional protection. It combines the toughness, lifespan and engineering design of wood-plastic composite materials. The extrusion process gives it the advantages of high resistance, UV resistance and ultra-low maintenance cost. It does not require painting, just regular cleaning to keep it looking like new. There are six colors to from, with clear wood grain and the richness and texture of natural wood.

PVC室内--PUR热胶覆膜系列--格栅类 PVC Indoor--PUR hot glue film series--Grid class

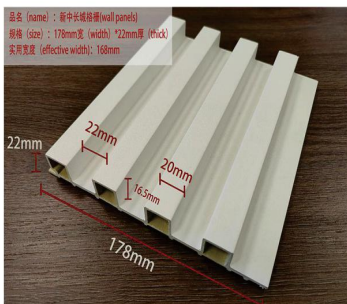

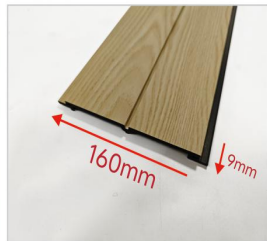
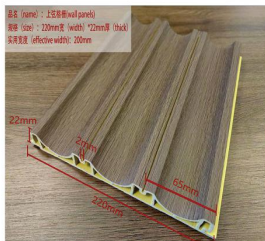
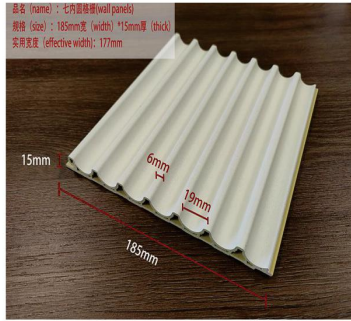
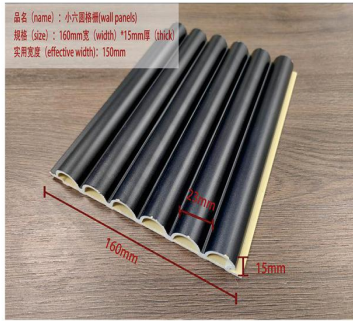
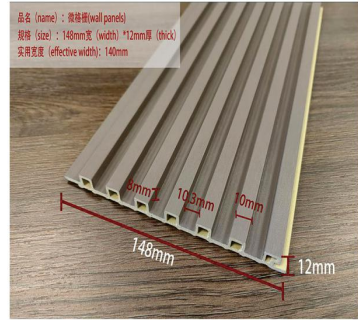

PVC室内--PUR热胶覆膜系列--天花、方通类 PVC Indoor--PUR hot glue film series--Smallpox, Fang Tong

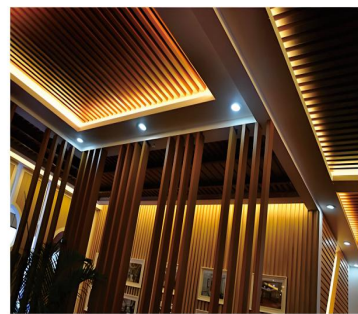
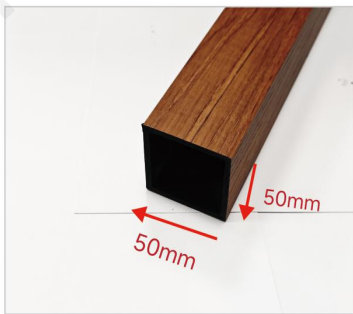
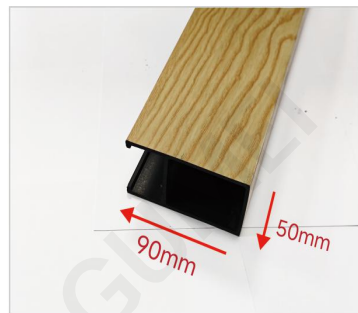
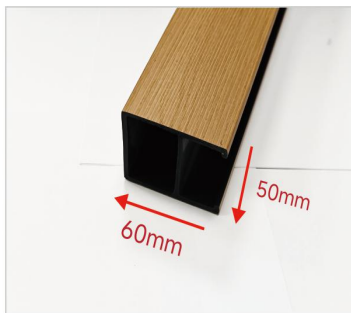

PUR GLUE PVC INDOOR

Various of Designs

品名 (name) : 微格栅(wall panels)
规格 (size) : 148mm宽 (width) *12mm厚 (thick)
实用宽度 (effective width): 140mm

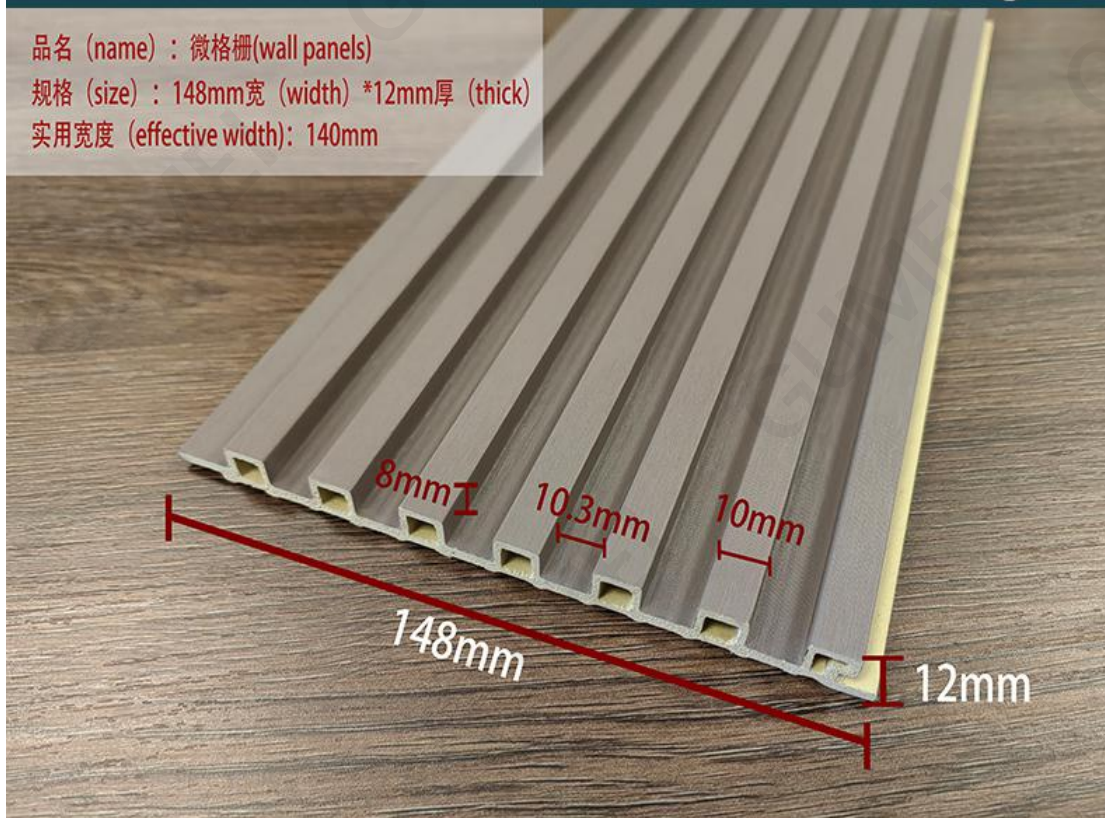

PVC 室内

PUR环保热胶覆膜



PUR GLUE PVC INDOOR

Various of Designs

品名 (name) : 大长城格栅 (wall panels)
规格 (size) : 202mm宽 (width) *14mm厚 (thick)
实用宽度 (effective width) : 192mm



PVC 室内

PUR环保热胶覆膜



PUR GLUE PVC INDOOR

Various of Designs

品名 (name): 高长城 (indoor wall panel)
规格 (size): 204mm宽 (width)*30mm厚 (thick)
实用宽度 (effective width): 195mm

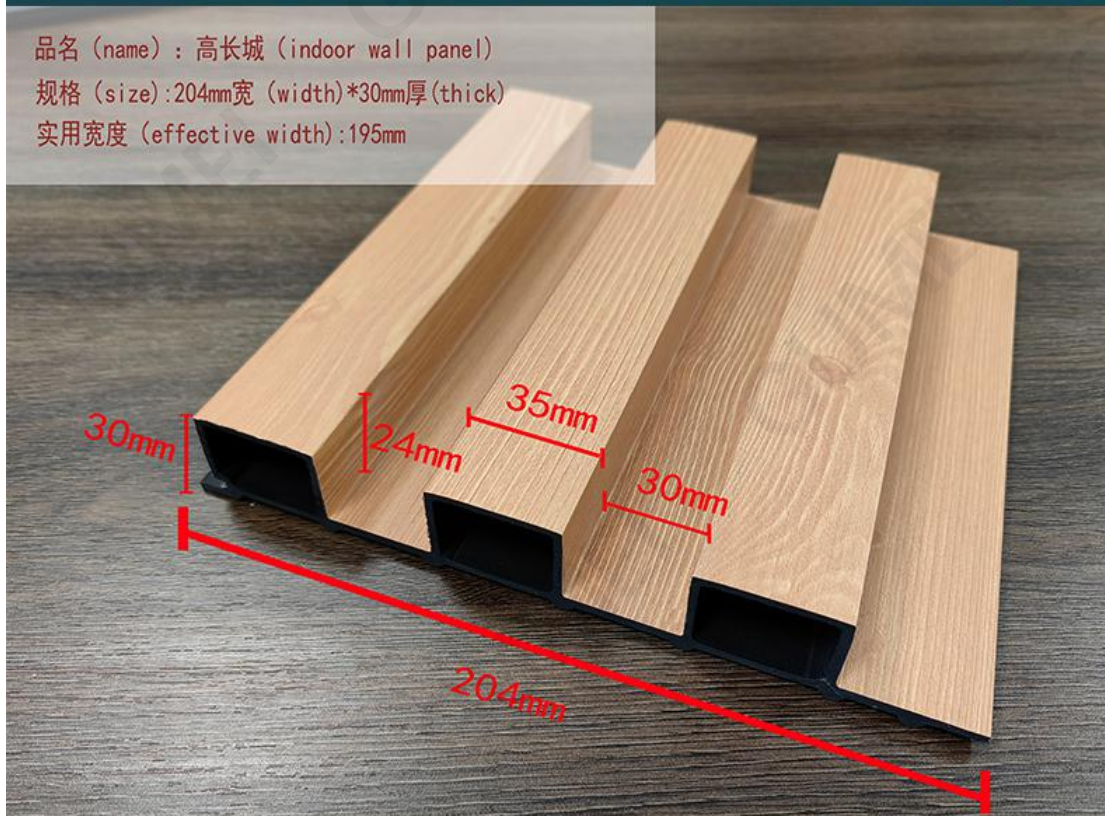

PVC 室内

PUR环保热胶覆膜



PUR GLUE PVC INDOOR

Various of Designs

品名 (name) : 七内圆格栅(wall panels)
规格 (size) : 185mm宽 (width) *15mm厚 (thick)
实用宽度 (effective width): 177mm

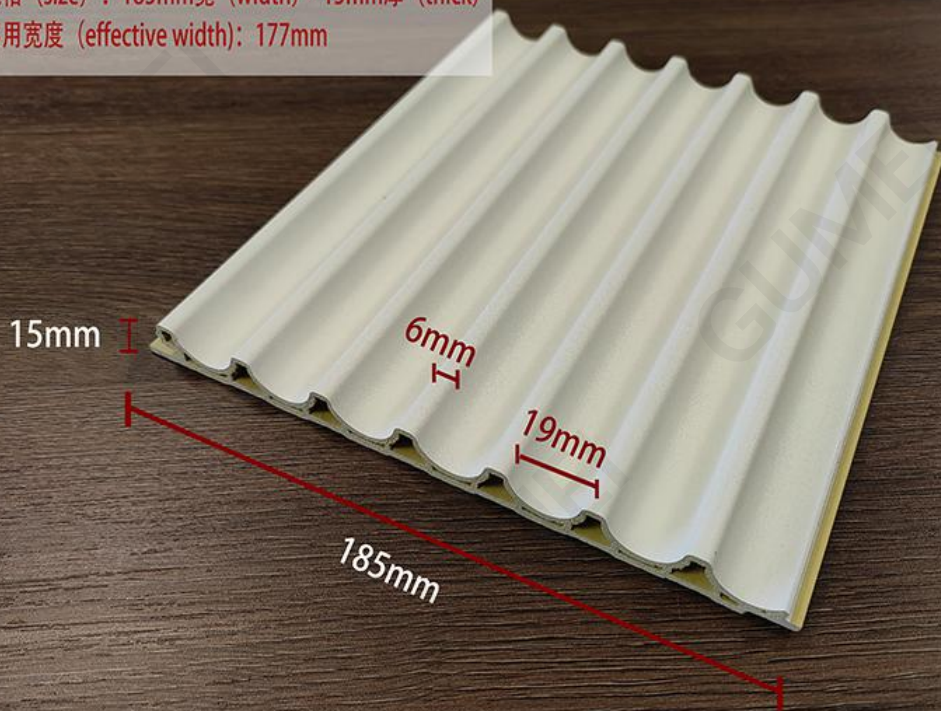

PVC 室内

PUR环保热胶覆膜



PUR GLUE PVC INDOOR

Various of Designs

品名 (name) : 上弦格栅(wall panels)
规格 (size) : 220mm宽 (width) *22mm厚 (thick)
实用宽度 (effective width): 200mm

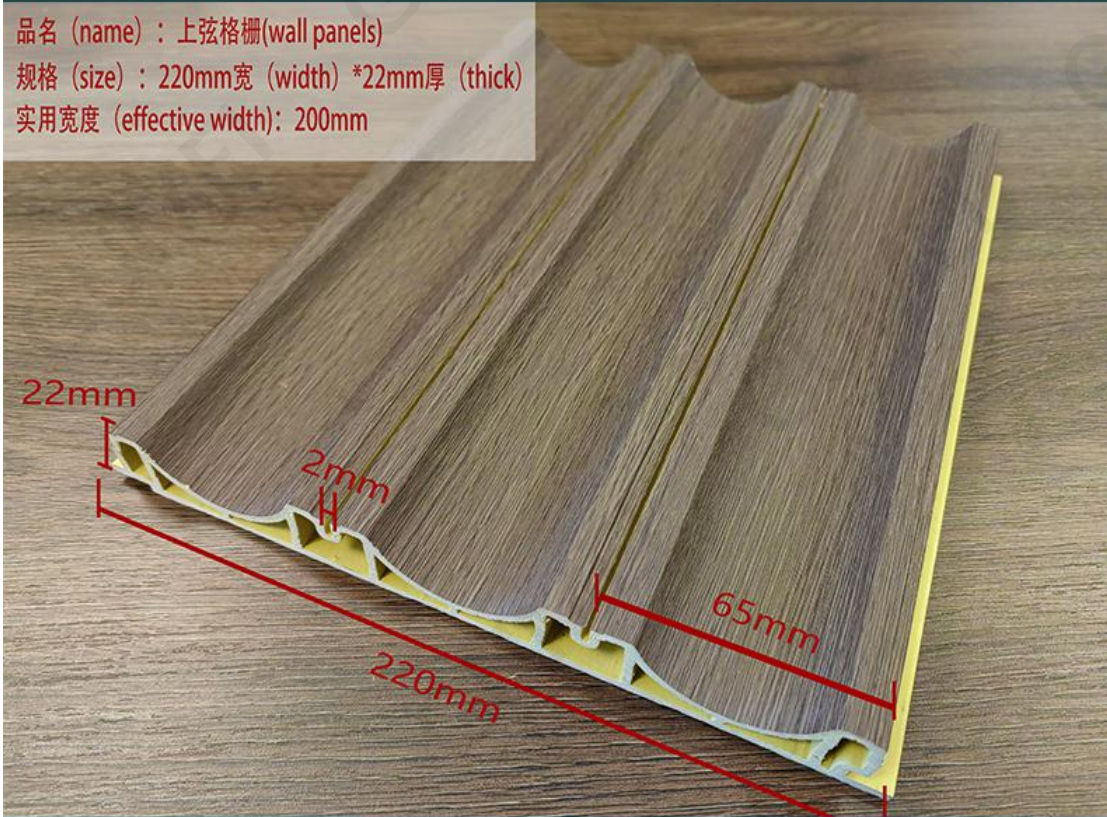

PVC 室内

PUR环保热胶覆膜



PUR GLUE PVC INDOOR

Various of Designs

品名 (name) : 小六圆格栅(wall panels)
规格 (size) : 160mm宽 (width) *15mm厚 (thick)
实用宽度 (effective width): 150mm

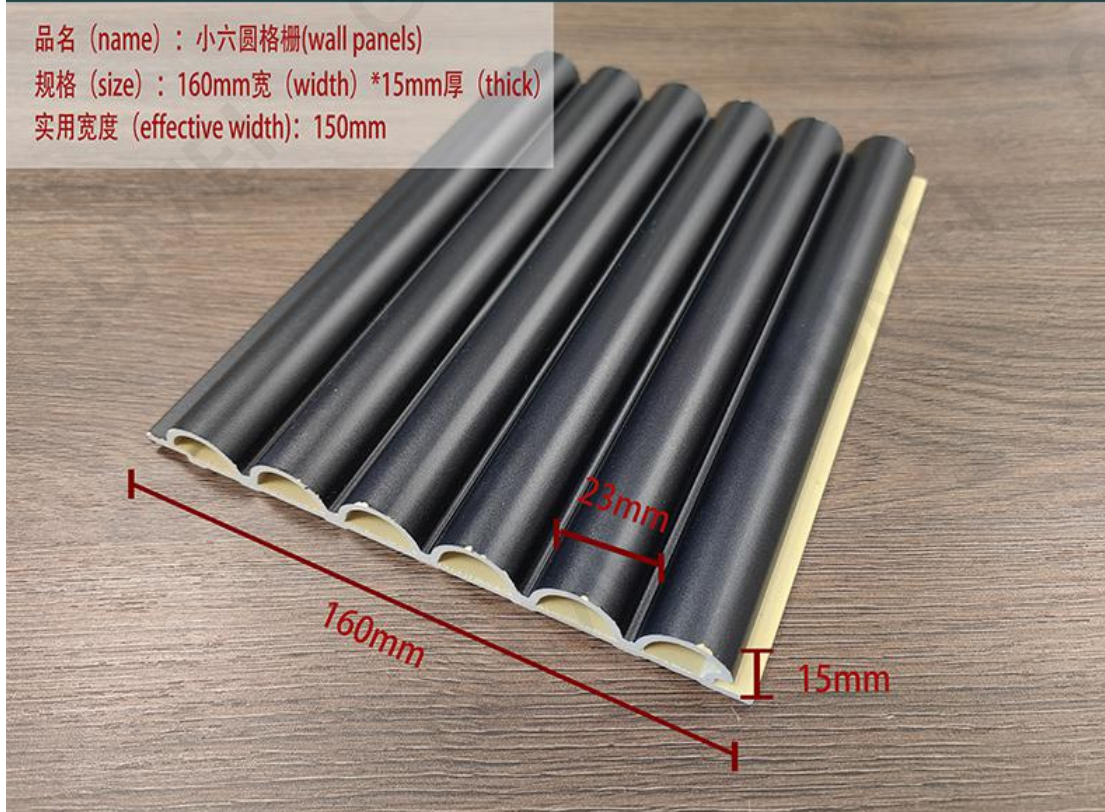

PVC 室内

PUR环保热胶覆膜



PUR GLUE PVC INDOOR

Various of Designs

品名 (name) : 小长城格栅(wall panels)
规格 (size) : 159mm宽 (width) *9mm厚 (thick)
实用宽度 (effective width): 150mm

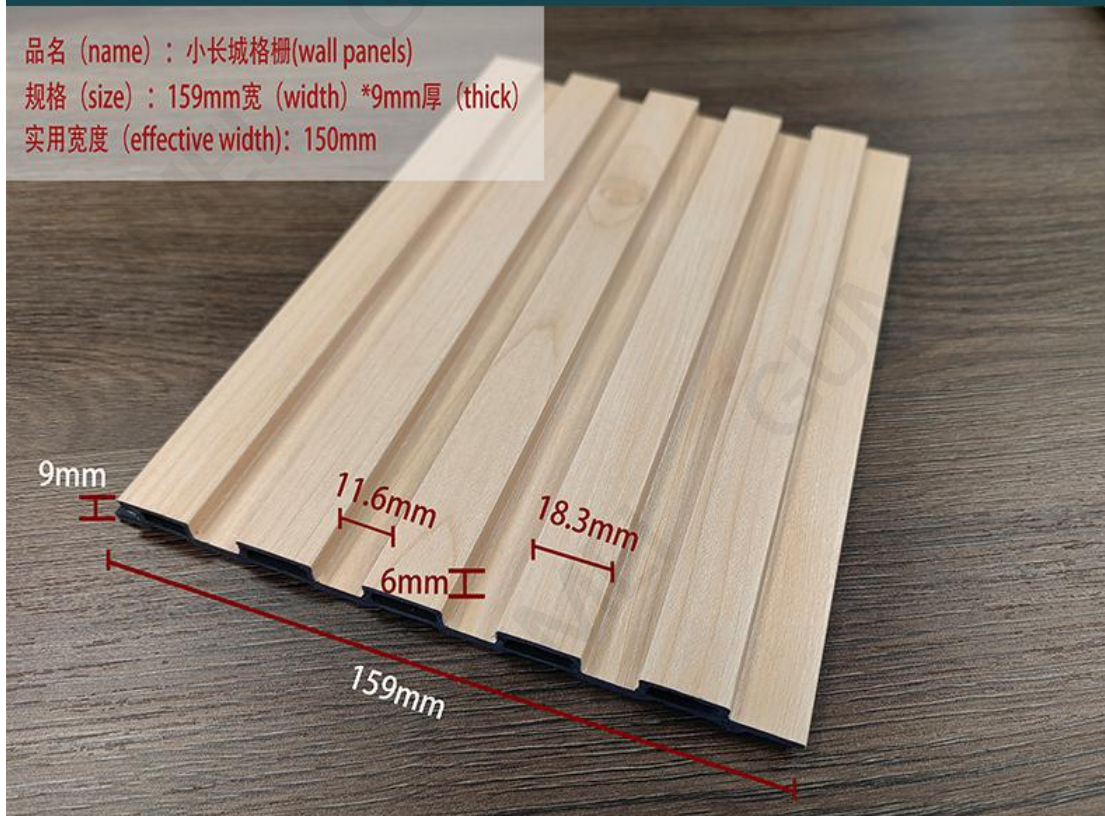

PVC 室内

PUR环保热胶覆膜

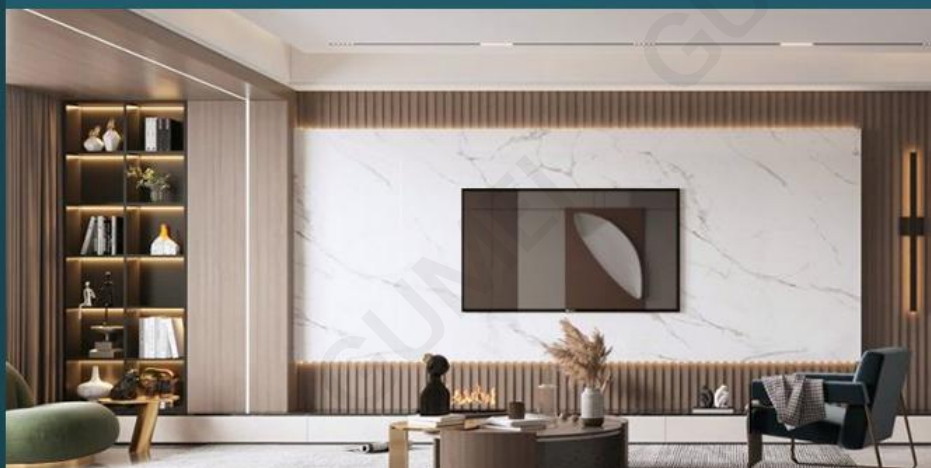

PUR GLUE PVC INDOOR

Various of Designs

品名 (name) : 新中长城格栅(wall panels)
规格 (size) : 178mm宽 (width) *22mm厚 (thick)
实用宽度 (effective width): 168mm

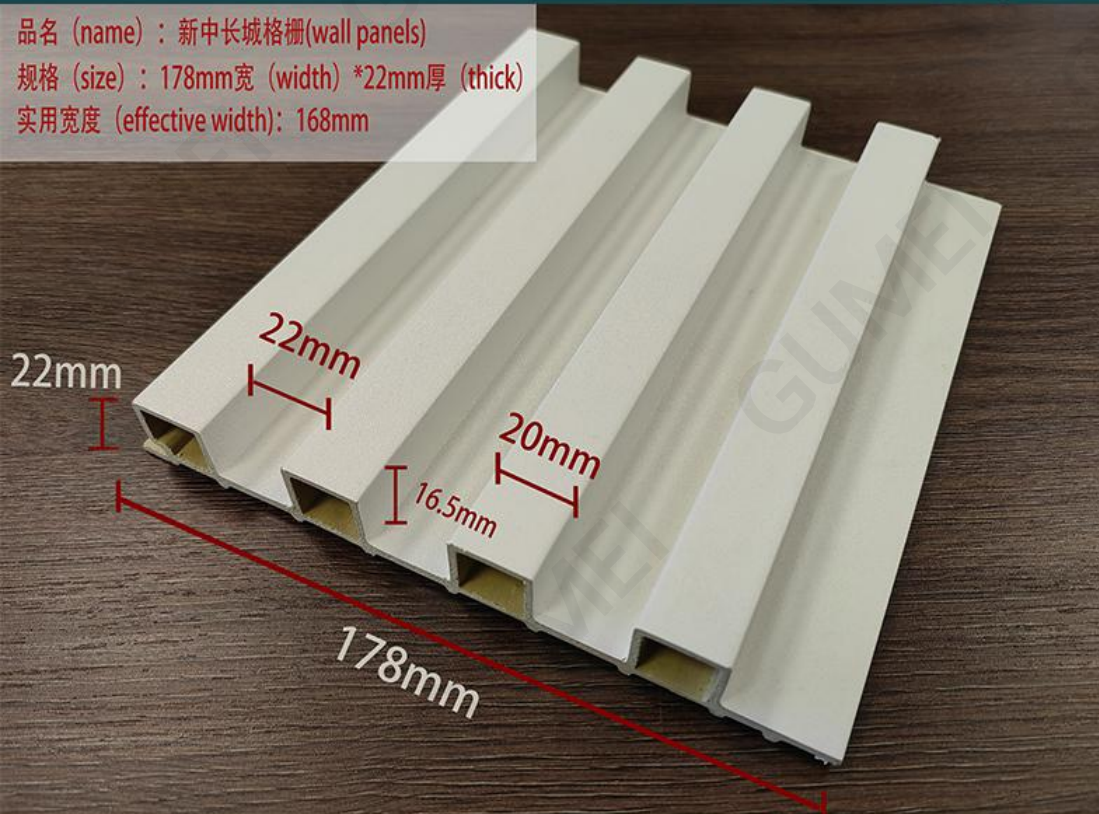

PVC 室内

PUR环保热胶覆膜



PUR GLUE PVC INDOOR

Various of Designs

品名 (name): 圆形格栅 (wall panel)
规格 (size): 204mm宽 (width)*30mm厚 (thick)
实用宽度 (effective width): 195mm



PVC 室内

PUR环保热胶覆膜



PUR GLUE PVC INDOOR

Various of Designs

品名 (name) : 子母格栅(wall panels)
规格 (size) : 149mm宽 (width) *13.5mm厚 (thick)
实用宽度 (effective width): 140mm

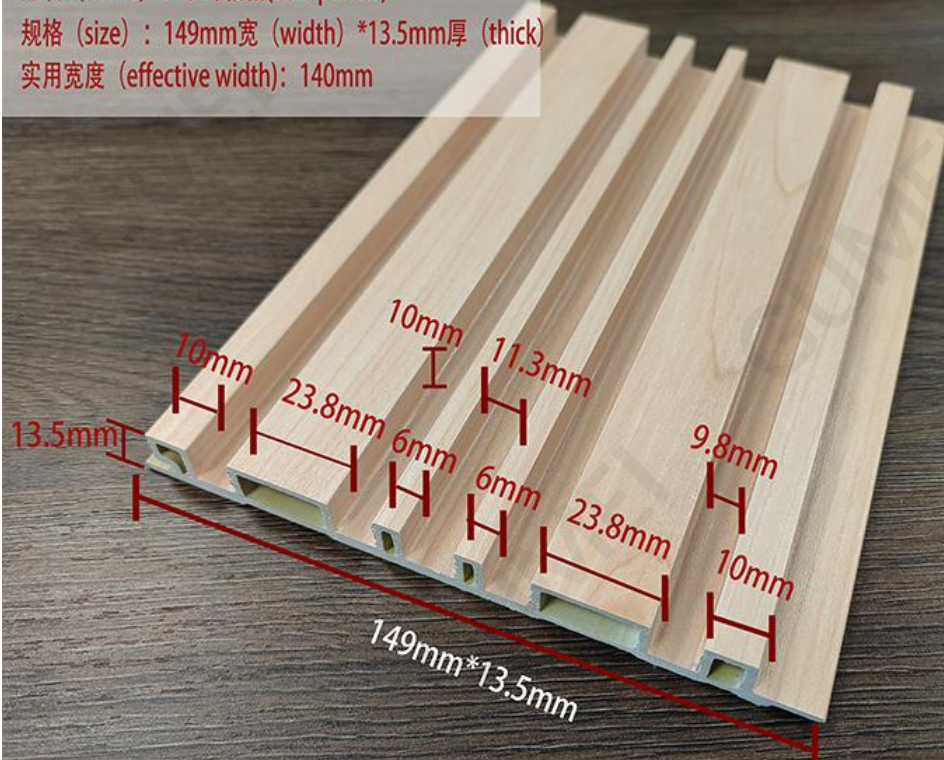

PVC 室内

PUR环保热胶覆膜



PUR GLUE PVC INDOOR

Various of Designs

品名 (name) : 160格栅 (wall panel)
规格 (size) : 160mm宽 (width)*18mm厚 (thick)
实用宽度 (effective width) : 150mm



PVC 室内

PUR环保热胶覆膜



PUR GLUE PVC INDOOR

Various of Designs

品名 (name) : 152格栅 (indoor wall panel)
规格 (size) : 152mm宽 (width)*16mm厚 (thick)
实用宽度 (effective width) : 145mm

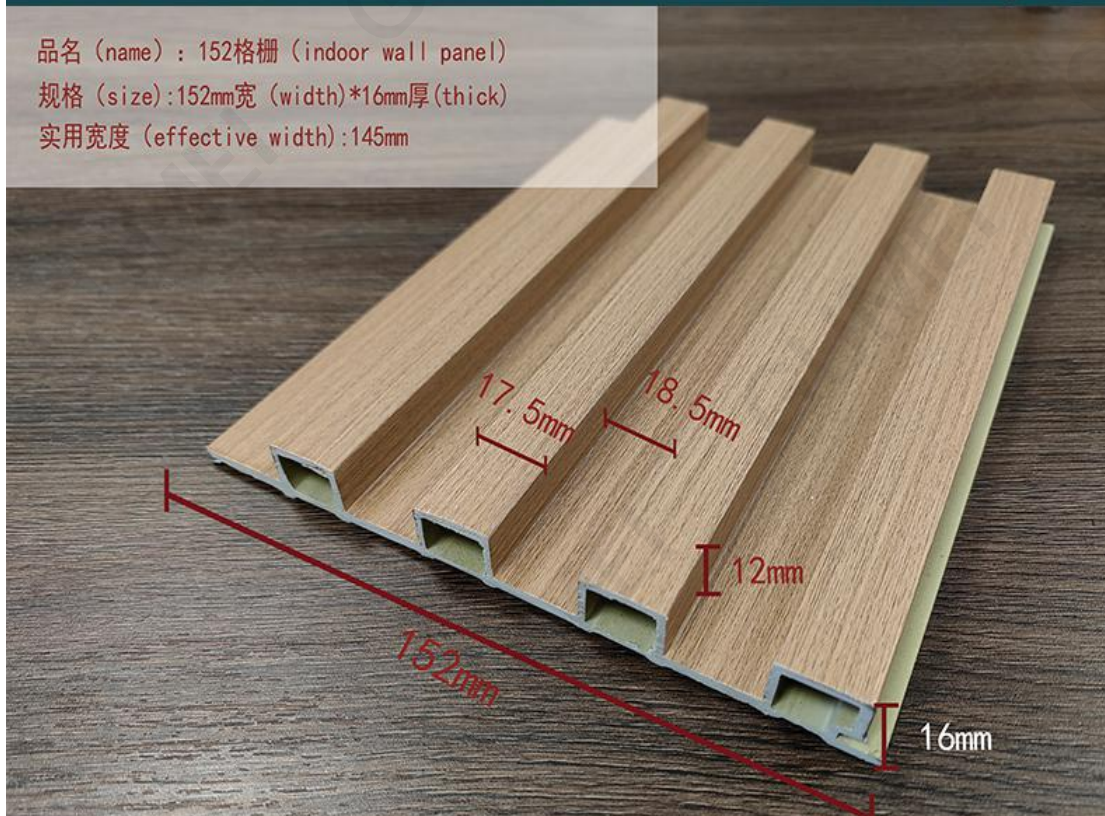

PVC 室内

PUR环保热胶覆膜



WPC OUTDOOR

Plastic Wood, as its name suggests, is made primarily of plastic, which is mixed with wood flour fiber plants to form new wood-based materials, which are then processed into plastics by extrusion, molding, injection molding, etc. , a sheet or profile produced.

WPC 户外

塑木材料，顾名思义可理解为主要以塑料为原料，通过添加木粉植物纤维混合成新的木质材料，再经挤压、模压、注射成型等塑料加工工艺，生产出的板材或型材。

户外一代PE塑木系列 Outdoor Generation PE Plastic Wood Series

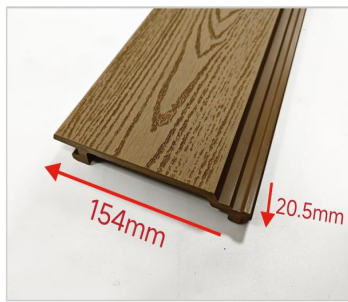
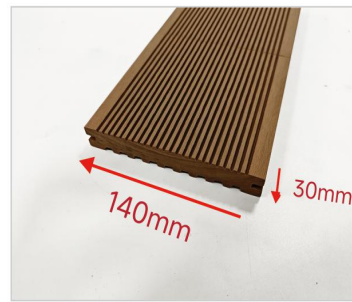
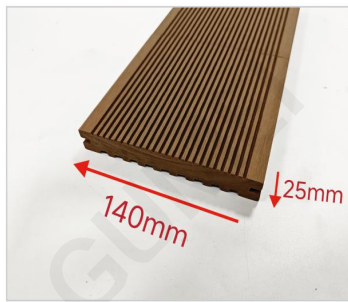
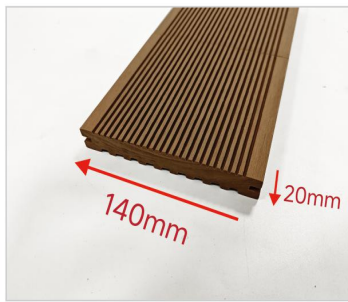
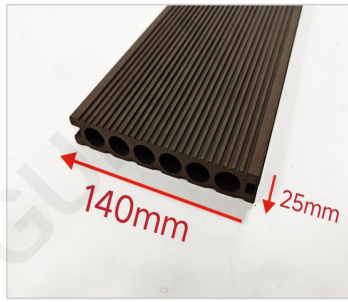

地板安装指引 Floor installation guide



DIY 地板 DIY floor

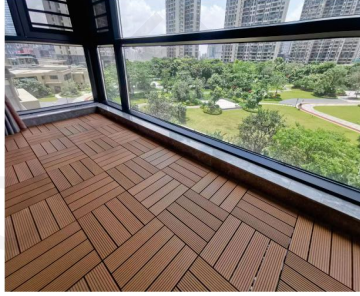
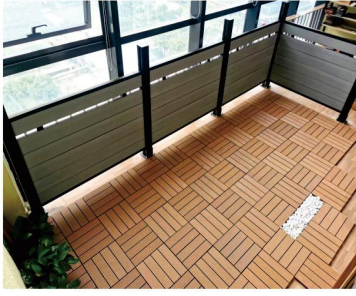

品名 (name): 户外塑木地板 (outdoor wpc floor)
规格 (size): 300mm宽 (width)*300mm长 (length)*20mm厚 (thick)
结构 (Structure): 实心-热压 (Solid, hot pressed)



品名 (name): 户外塑木地板 (outdoor wpc floor)
规格 (size): 300mm宽 (width)*300mm长 (length)*20mm厚 (thick)
结构 (Structure): 实心-共挤 (Solid, co-extrusion)



品名 (name): 户外塑木地板 (outdoor wpc floor)
规格 (size): 300mm宽 (width)*300mm长 (length)*20mm厚 (thick)
结构 (Structure): 实心-防滑槽 (Solid, one-sided anti-slip channel)

户外二代PE围栏、立柱、方通 Outdoor second-generation PE fence, posts, square tubes



品名 (name): 户外塑木立柱 (outdoor wpc column)
规格 (size): 120mm宽 (width)*120mm厚 (thick)
结构 (Structure): 空心-共挤 (Hollow, co-extrusion)



品名 (name): 户外塑木方通 (outdoor wpc column)
规格 (size): 100mm宽 (width)*50mm厚 (thick)
结构 (Structure): 空心-共挤 (Hollow, co-extrusion)



品名 (name): 户外塑木方通 (outdoor wpc column)
规格 (size): 50mm宽 (width)*50mm厚 (thick)
结构 (Structure): 空心-共挤 (Hollow, co-extrusion)



品名 (name): 户外塑木围栏板 (outdoor wpc fence board)
规格 (size): 181mm宽 (width)*20mm厚 (thick)
实用宽度 (effective width): 172mm
结构 (Structure): 方孔-共挤 (Square holes, Co-extrusion)

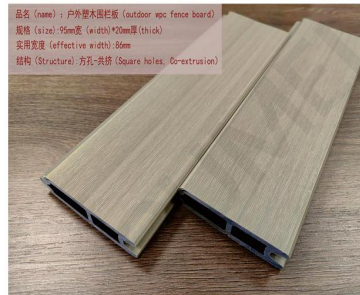

品名 (name): 户外塑木围栏板 (outdoor wpc fence board)
规格 (size): 95mm宽 (width)*20mm厚 (thick)
实用宽度 (effective width): 80mm
结构 (Structure): 方孔-共挤 (Square holes, Co-extrusion)



The first generation WPC OUTDOOR

Various of Designs

品名 (name) : 户外塑木地板 (outdoor wpc floor)

规格 (size) : 140mm宽 (width) * 35mm厚 (thick)

结构 (Structure) : 圆孔双面防滑槽

(Round Hole, double anti-skid groove)



WPC 户外

第一代塑木



The first generation WPC OUTDOOR

Various of Designs

品名 (name): 户外塑木地板 (outdoor wpc floor)

规格 (size): 140mm宽 (width)*25mm厚 (thick)

结构 (Structure): 方孔-双面防滑槽
(square hole, double side anti-skid groove)



WPC 户外

第一代塑木



The first generation WPC OUTDOOR

Various of Designs

品名 (name): 户外塑木地板 (outdoor wpc floor)

规格 (size): 140mm宽 (width)*25mm厚 (thick)

结构 (Structure): 圆孔-双面防滑槽

(Round hole-double side anti-skid groove)



WPC 户外

第一代塑木



The first generation WPC OUTDOOR

Various of Designs

品名 (name): 户外塑木地板 (outdoor wpc floor)

规格 (size): 140mm宽 (width)*25mm厚 (thick)

结构 (Structure): 实心-双面防滑槽
(Solid-double side anti-skid chute)



WPC 户外

第一代塑木



The first generation WPC OUTDOOR

Various of Designs

品名 (name) : 户外塑木地板 (outdoor wpc floor)

规格 (size) : 140mm宽 (width)*25mm厚 (thick)

结构 (Structure) : 圆孔-3D压纹
(Round hole-3D embossing)

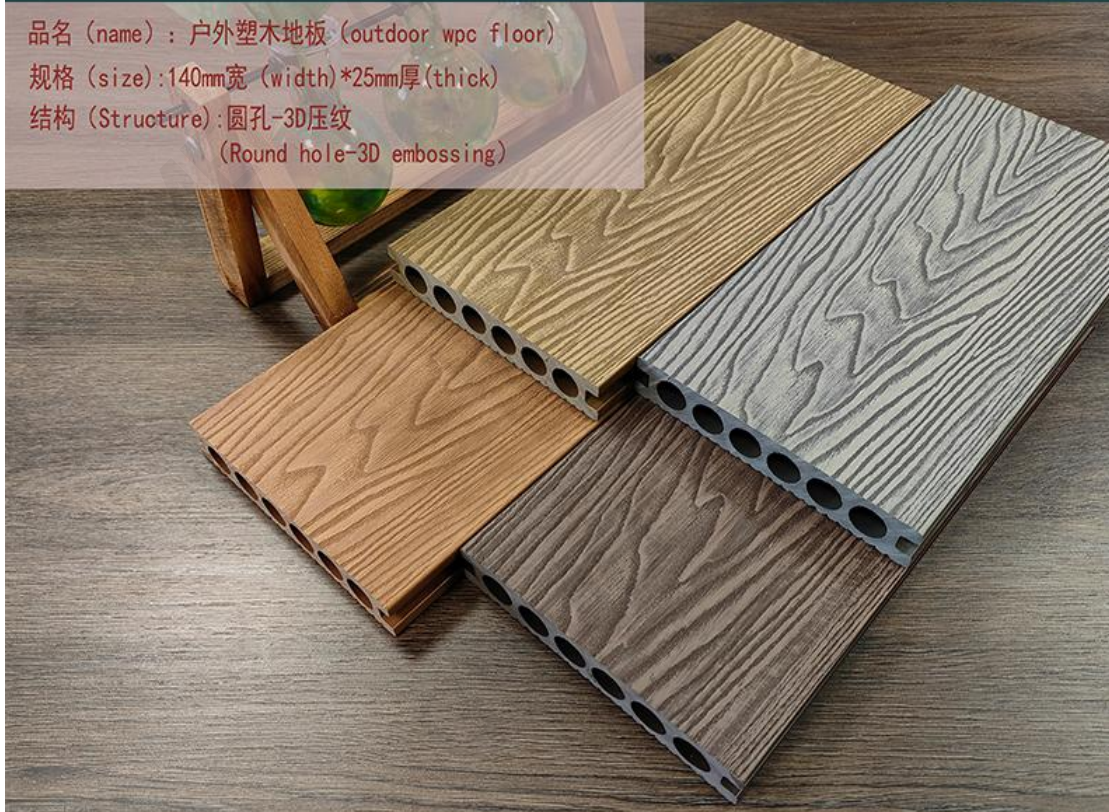

WPC 户外

第一代塑木



The first generation WPC OUTDOOR

Various of Designs

品名 (name): 户外塑木墙板 (outdoor wpc wall panel)

规格 (size): 154mm宽 (width)*21mm厚 (thick)

实用宽度 (effective width): 137mm

结构 (Structure): 实心-烫压 (Solid, hot pressed)



WPC 户外

第一代塑木



The first generation WPC OUTDOOR

Various of Designs

品名 (name): 户外塑木墙板 (outdoor wpc wall panel)

规格 (size): 219mm宽 (width)*26mm厚 (thick)

实用宽度 (effective width): 200mm

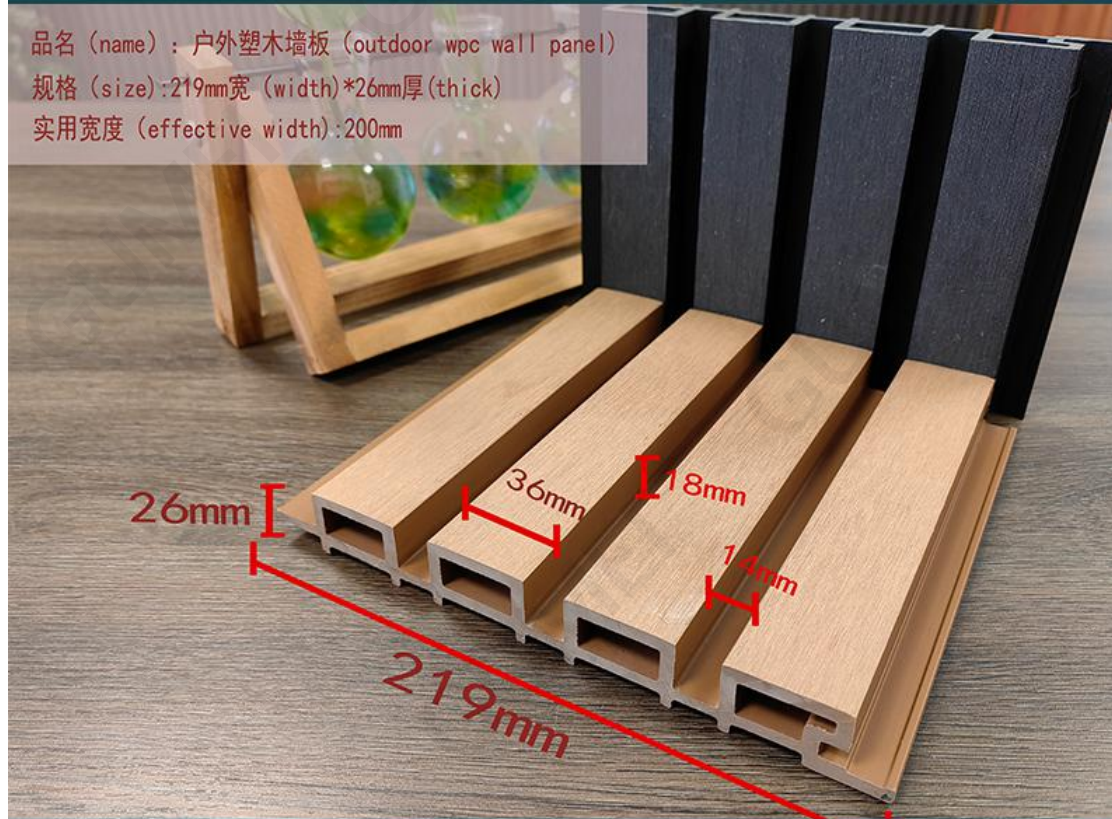

WPC 户外

第一代塑木

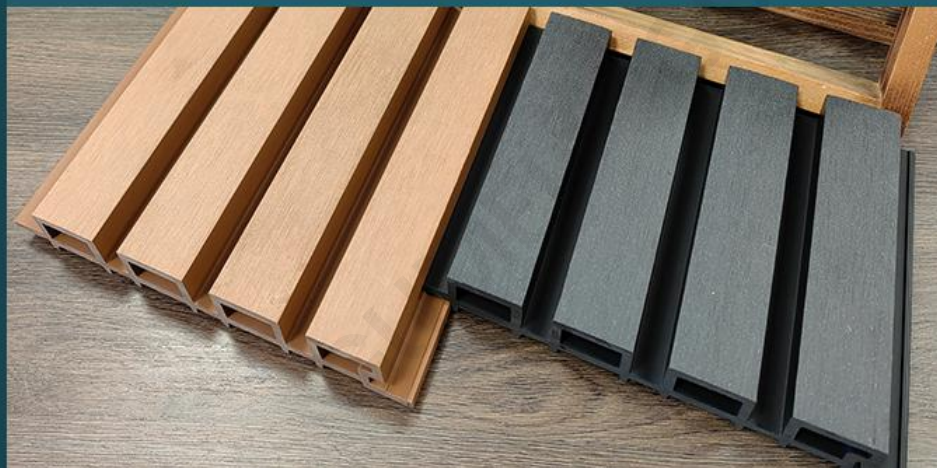

The first generation WPC OUTDOOR

Various of Designs

品名 (name): 户外塑木地板 (outdoor wpc floor)

规格 (size): 300mm宽 (width)*300mm长 (length)*20mm厚 (thick)

结构 (Structure): 实心-防滑槽
(Solid, one-sided anti-skid chute)



WPC 户外

第一代塑木



The first generation WPC OUTDOOR

Various of Designs

品名 (name): 户外塑木地板 (outdoor wpc floor)

规格 (size): 300mm宽 (width)*300mm长 (length)*20mm厚 (thick)

结构 (Structure): 实心-烫压
(Solid, hot pressed)



WPC 户外

第一代塑木



The second generation WPC OUTDOOR

Various of Designs

品名 (name): 户外塑木地板 (outdoor wpc floor)

规格 (size): 300mm宽 (width)*300mm长 (length)*20mm厚 (thick)

结构 (Structure): 实心-共挤
(Solid, co-extrusion)



WPC 户外

第二代塑木





户外二代PE共挤塑木系列

塑木材料，顾名思义可理解为主要以塑料为原料通过添加木粉植物纤维混合成新的木质材料，再经挤压、模压、注射成型等塑料加工工艺，生产出的板材或型材。

Outdoor second-generation PE co extruded plastic wood series

Plastic Wood, as its name suggests, is made primarily of plastic, which is mixed with wood flour fiber plants to form new wood-based materials, which are then processed into plastics by extrusion, molding, injection molding, etc., a sheet or profile produced.

户外二代PE共挤塑木系列 Outdoor second-generation PE co extruded plastic wood series

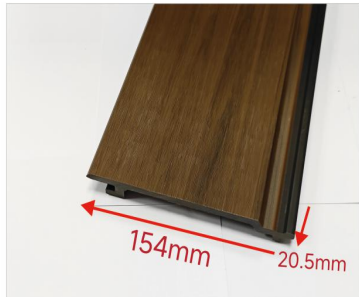
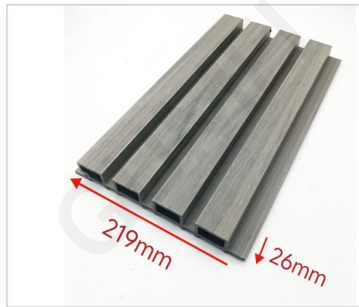

The Second generation WPC OUTDOOR

Various of Designs

品名 (name): 户外塑木地板 (outdoor wpc floor)

规格 (size): 138mm宽 (width)*22mm厚 (thick)

结构 (Structure): 圆孔-共挤 (Round hole-co-extrusion)

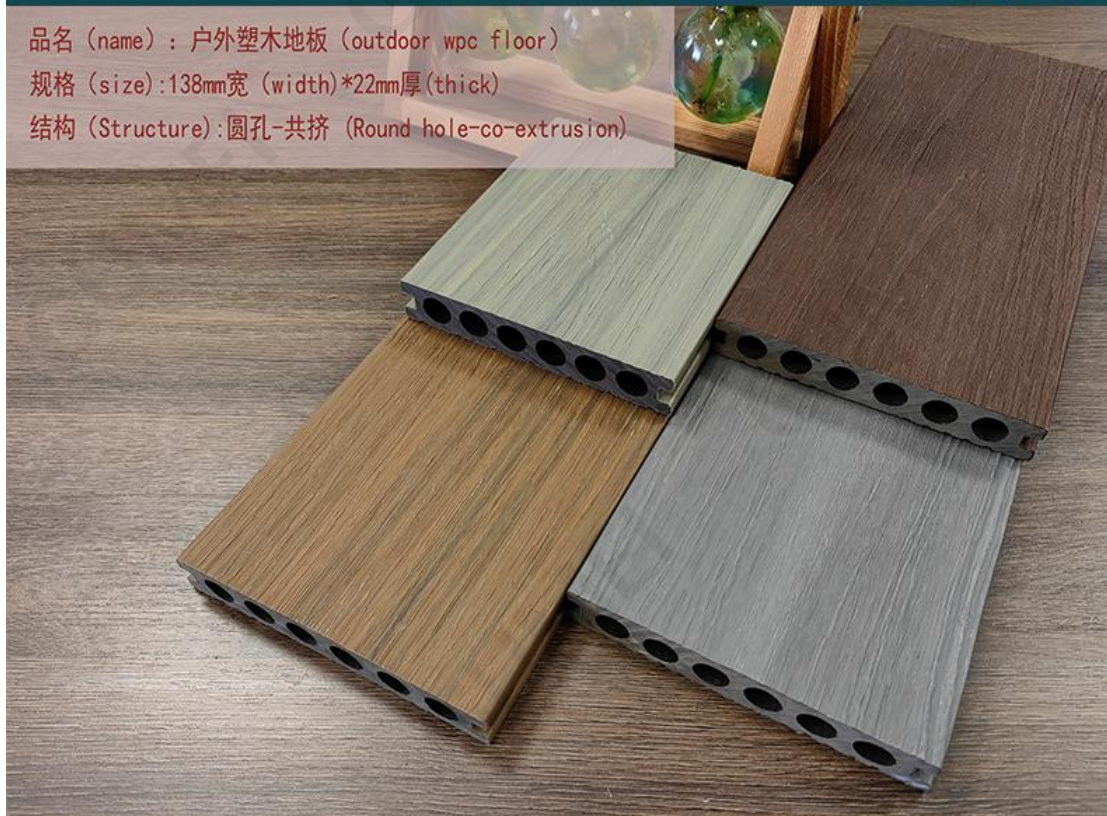

WPC 户外

第二代共挤塑木

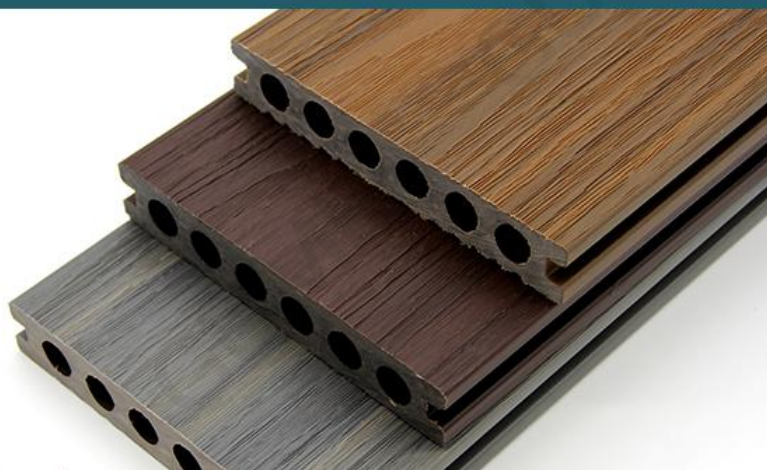

The Second generation WPC OUTDOOR

Various of Designs

品名 (name): 户外塑木地板 (outdoor wpc floor)

规格 (size): 138mm宽 (width)*22mm厚 (thick)

结构 (Structure): 实心-共挤 (Solid, Co-extrusion)

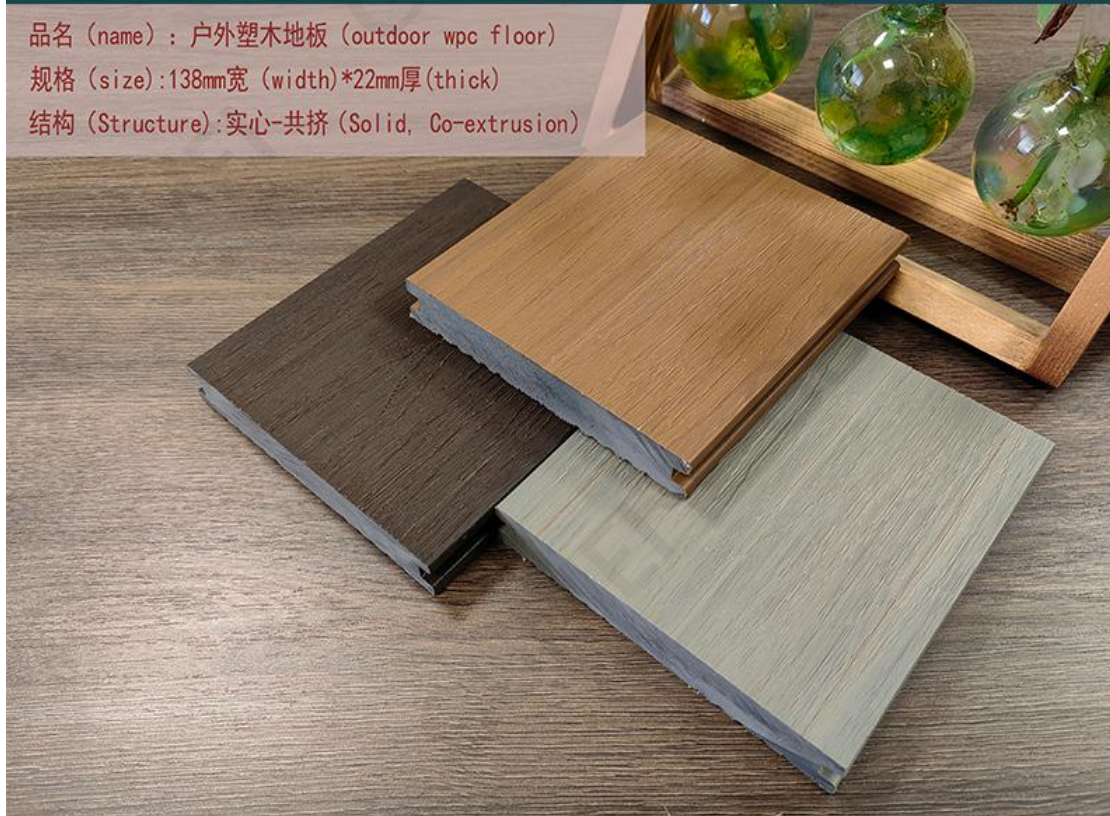

WPC 户外

第二代共挤塑木



The Second generation WPC OUTDOOR

Various of Designs

品名 (name): 户外塑木墙板 (outdoor wpc wall panel)

规格 (size): 154mm宽 (width)*21mm厚 (thick)

实用宽度 (effective width): 137mm

结构 (Structure): 实心-共挤 (Solid, Co-extrusion)

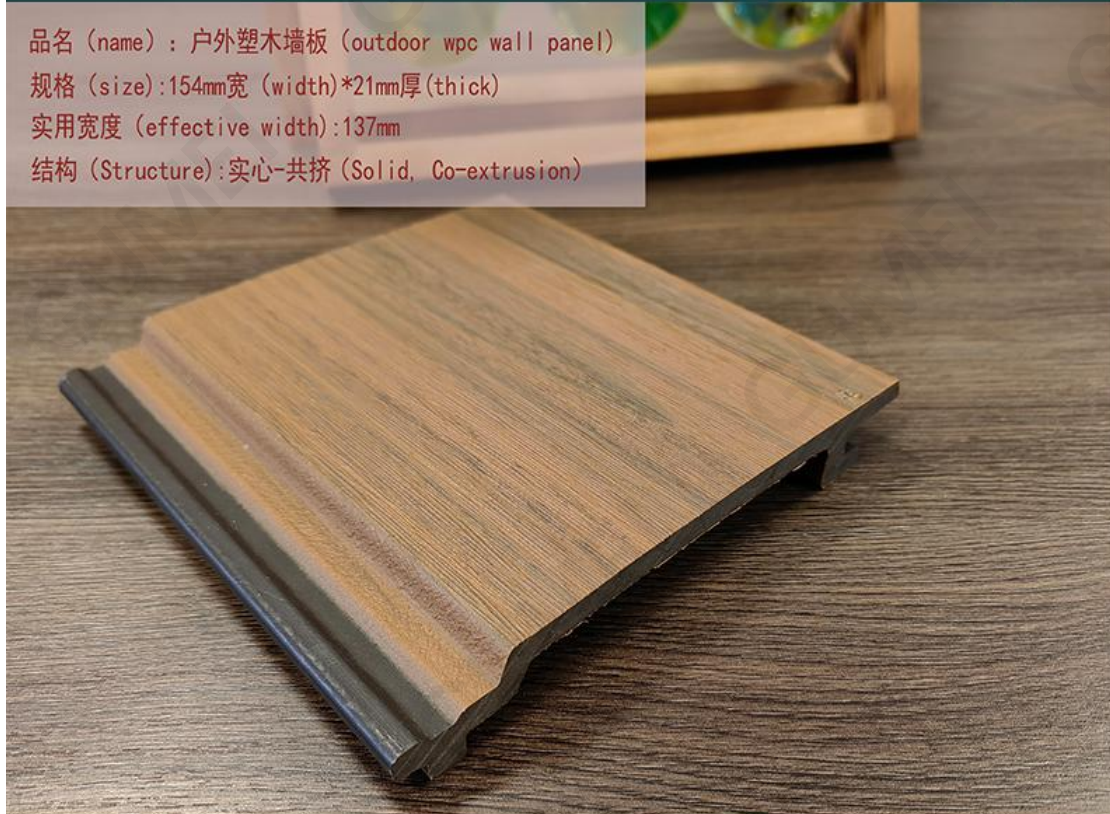

WPC 户外

第二代共挤塑木



The Second generation WPC OUTDOOR

Various of Designs

品名 (name): 户外塑木围栏板 (outdoor wpc fence board)

规格 (size): 95mm宽 (width)*20mm厚 (thick)

实用宽度 (effective width): 86mm

结构 (Structure): 方孔-共挤 (Square holes, Co-extrusion)

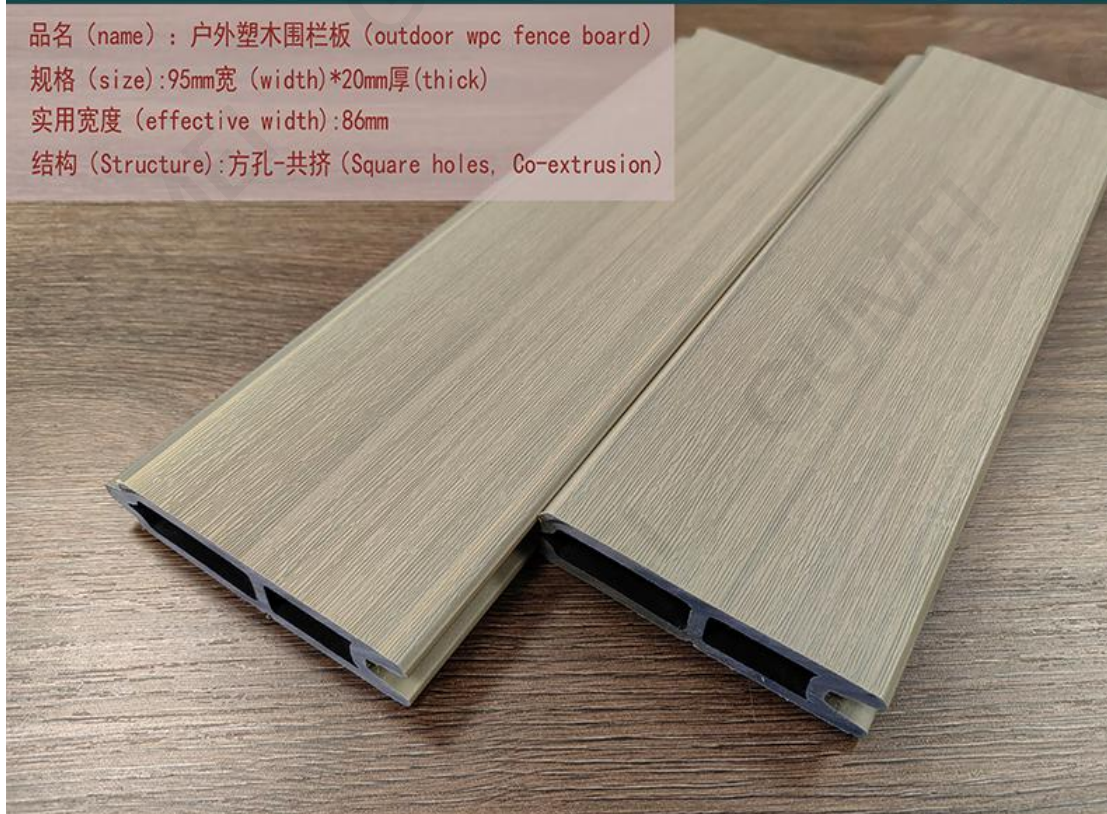

WPC 户外

第二代共挤塑木



The Second generation WPC OUTDOOR

Various of Designs

品名 (name): 户外塑木围栏板 (outdoor wpc fence board)

规格 (size): 181mm宽 (width)*20mm厚 (thick)

实用宽度 (effective width): 172mm

结构 (Structure): 方孔-共挤 (Square holes, Co-extrusion)

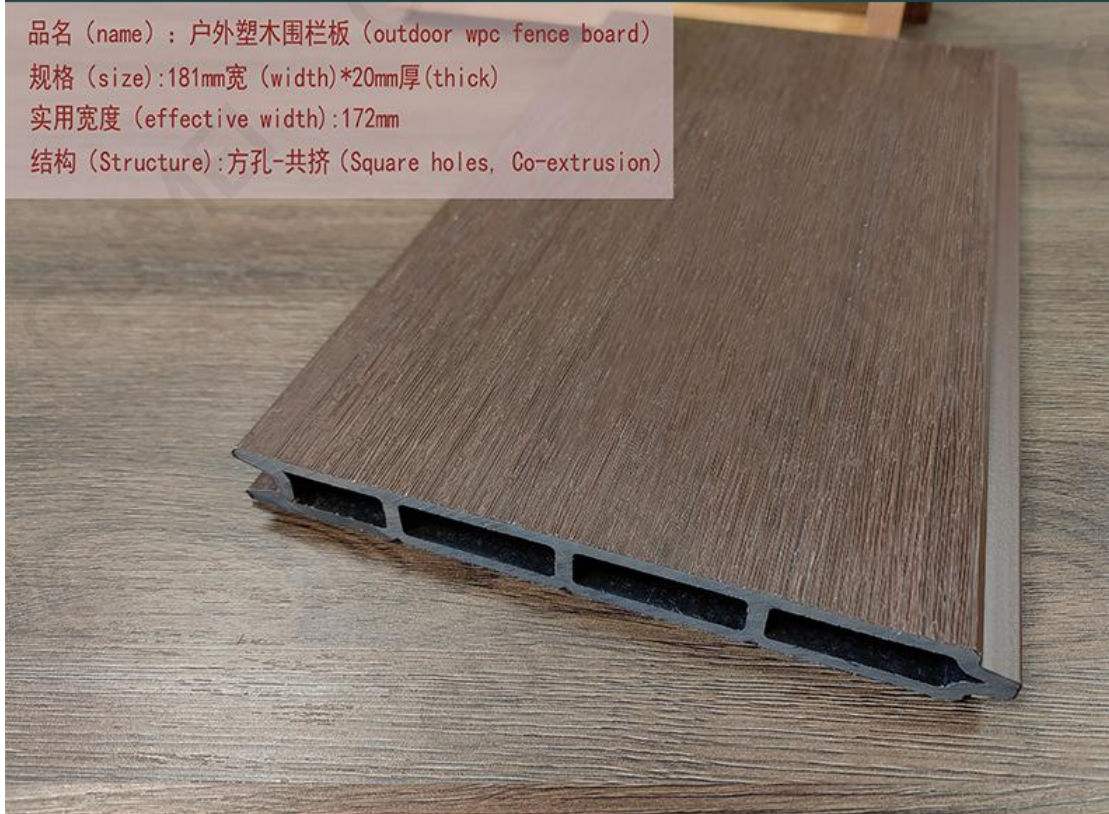

WPC 户外

第二代共挤塑木



The second generation WPC OUTDOOR

Various of Designs

品名 (name): 户外塑木立柱 (outdoor wpc column)

规格 (size): 120mm宽 (width)*120mm厚 (thick)

结构 (Structure): 空心-共挤
(Hollow, co-extrusion)



WPC 户外

第二代塑木



The second generation WPC OUTDOOR

Various of Designs

品名 (name): 户外塑木方通 (outdoor wpc column)

规格 (size): 100mm宽 (width)*50mm厚 (thick)

结构 (Structure): 空心-共挤
(Hollow, co-extrusion)



WPC 户外

第二代塑木

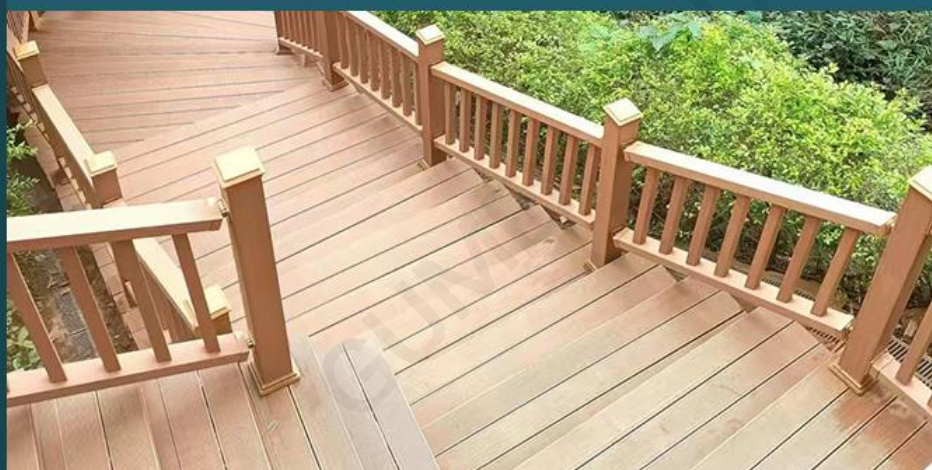

The second generation WPC OUTDOOR

Various of Designs

品名 (name) : 户外塑木方通 (outdoor wpc column)

规格 (size) : 50mm宽 (width) * 50mm厚 (thick)

结构 (Structure) : 空心-共挤
(Hollow, co-extrusion)



WPC 户外

第二代塑木



The second generation WPC OUTDOOR

Various of Designs

品名 (name): 户外塑木长城板 (outdoor wpc wall panel)

规格 (size): 219mm宽 (width)*26mm厚 (thick)

实用宽度 (effective width): 200mm

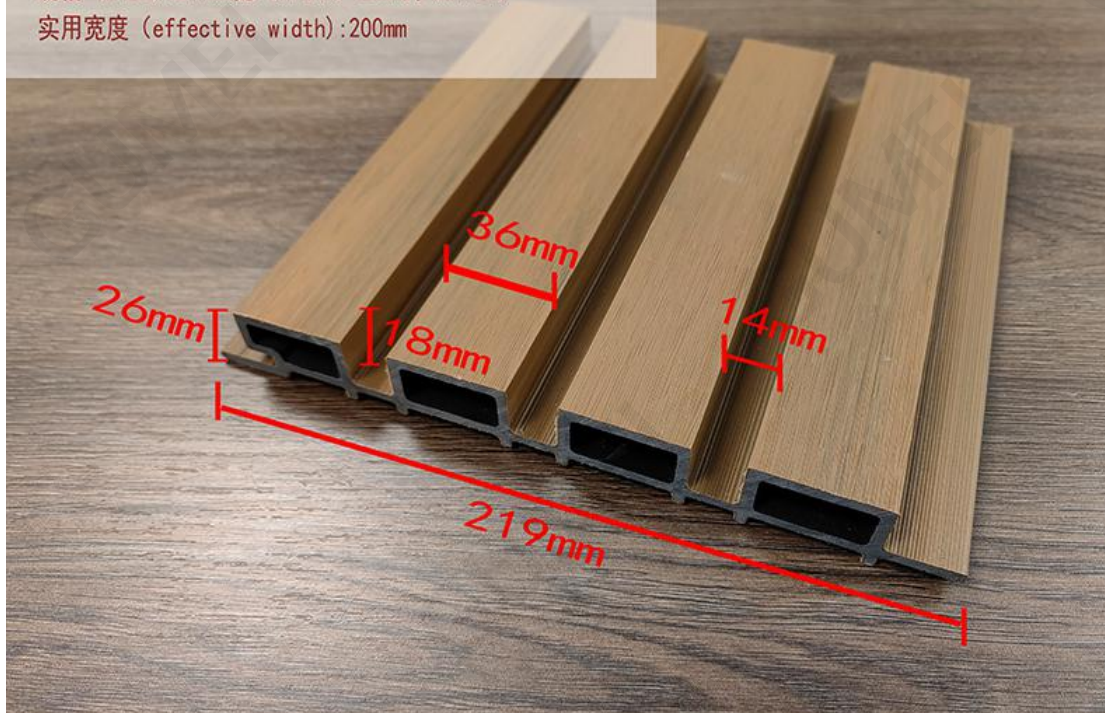

WPC 户外

第二代塑木



The second generation WPC OUTDOOR

Various of Designs

品名(name): 户外长城板 (outdoor wall panel)
尺寸(size): 219mm宽 (width) *26mm厚 (thick)
实用宽度 (effective width): 200mm

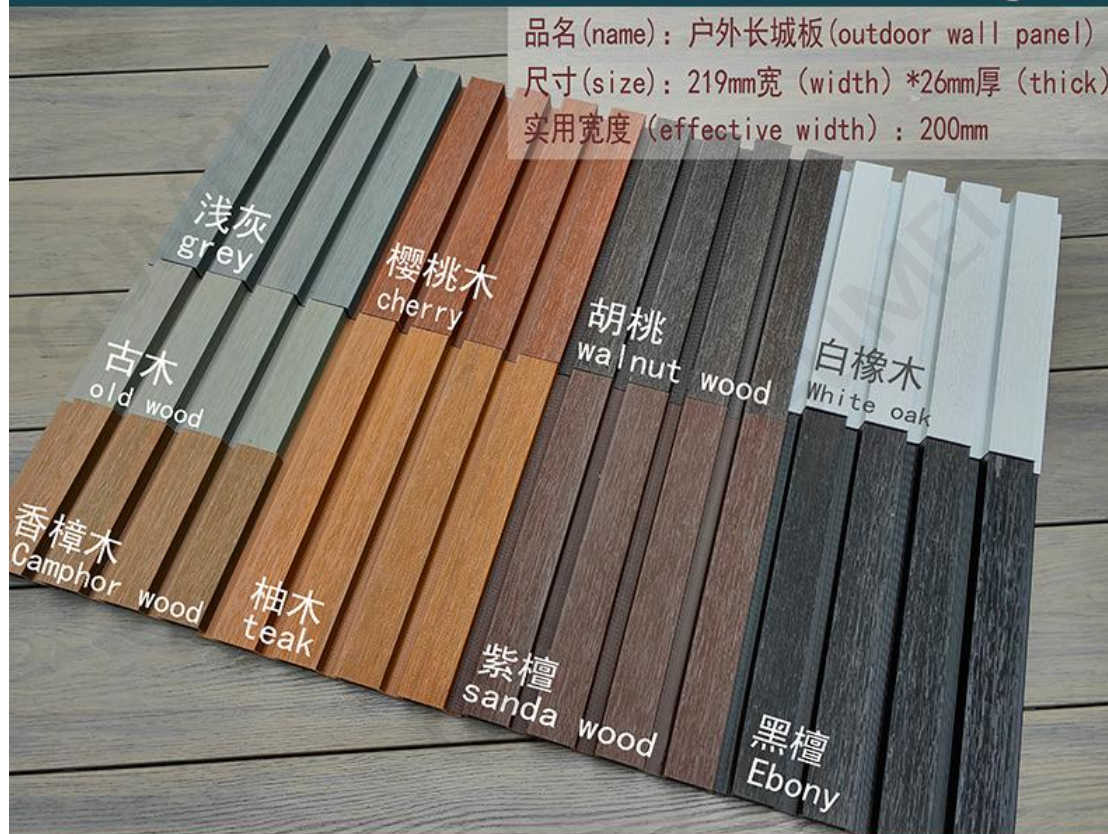

WPC 户外

第二代塑木

